

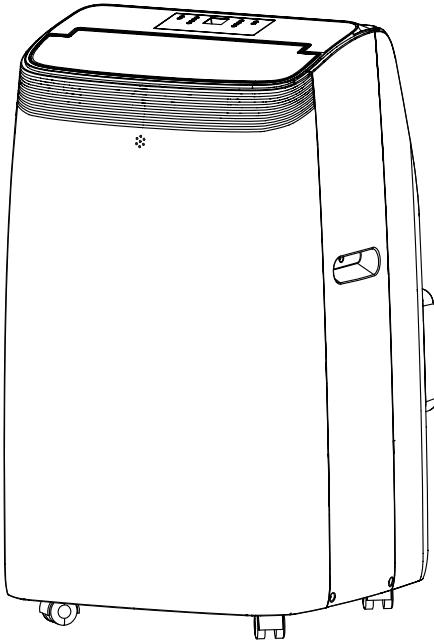

PORTABLE AIR CONDITIONER

PAG Series

USER MANUAL



For models:

PAG-Y11KC0730C

PAG-Y14KCO790C

*Thank you for selecting our quality appliance.
Please be sure to read this user manual carefully before using.
Any question, please contact the professional service for help.*

IMPORTANT: The remote control and hardware necessary to use your new product is included inside the box. You will find them inserted in the Styrofoam included in the box.

TABLE OF CONTENTS

Important safeguards	3
Parts name	5
Installation instructions.....	7
Description of the display screen.....	10
Remote control manual.....	13
Tips for correct use	16
Water drainage method.....	17
Cleaning	18
Start-end of season operations.....	18
Troubleshooting	19

IMPORTANT SAFEGUARDS

This appliance is for household use only.

- Disconnect the appliance from its power source during service and when replacing parts and cleaning.
- Please note: Check the nameplate for the type of refrigerant gas used in your appliance.
- Specific information regarding appliances with refrigerant gas. The appliance is recommended not to pierce the cooling circuit of the machine. At the end of its useful life, deliver the appliance to a special waste collection centre for disposal. GWP(Global Warming Potential): R410A: 2088, R134a: 1430, R290: 3, R32: 675.
- This hermetically sealed system contains fluoridated greenhouse gases.
- ENVIRONMENTAL INFORMATION: This unit contains fluoridated greenhouse gases covered by the Kyoto Protocol.
- Do not use this unit for functions other than those described in this instruction manual.
- Make sure the plug is inserted firmly and completely into the outlet. It can result in the risk of electric shock or fire.
- Do not plug other appliances into the same outlet, it can result in the risk of electric shock.
- Do not disassemble or modify the appliance or the power cord, it can result in the risk of electric shock or fire. All other services should be referred to a qualified technician.
- Do not place the power cord or appliance near a heater, radiator, or other heat source. It can result in the risk of electric shock or fire.
- This unit is equipped with a cord that has a grounded wire connected to a grounded pin or grounding tab. The plug must be plugged into a socket that is properly installed and grounded. Do not under any circumstances cut or remove the grounded pin or grounding tab from this plug.
- The unit should be used or store in such a way that it is protected from moisture e.g. condensation, splashed water, etc. Unplug unit immediately if this occurs.
- Always transport your appliance in a vertical position and place on a stable, level surface during use. If the unit is transported laying on its side it should be stood up and left unplugged for 6 hours.
- Always use the switch on the control panel or remote control to turn the unit off, and do not start or stop operation by plugging in or unplugging the power cord. It can result in the risk of electric shock.
- Do not touch the buttons on the control panel with your wet and damp fingers.
- Do not use hazardous chemicals to clean or come into contact with the unit. To prevent damage to the surface finish, use only a soft cloth to clean the appliance. Do not use wax, thinner, or a strong detergent. Do not use the unit in the presence of inflammable substance or vapour such as alcohol, insecticides, gasoline, etc.
- If the appliance is making unusual sounds or is emitting smoke or an unusual odor, unplug it immediately.
- Do not clean the unit with water. Water can enter the unit and damage the insulation, creating a shock hazard. If water enters the unit, unplug it immediately and contact Customer Service.
- Utilize two or more people to lift and install the unit.
- Always grasp the plug when plugging in or unplugging the appliance. Never unplug by pulling on the cord. It can result in the risk of electrical shock and damage.
- Install the appliance on a sturdy, level floor capable of supporting up to 110lbs (50kg). Installation on a weak or unlevel floor can result in the risk of property damage and personal injury.

Electrical connections

Before plugging the appliance into the mains socket, check that:

- The mains power supply corresponds to the value indicated on the rating plate on the back of the appliance.
- The power socket and electrical circuit are adequate for the appliance.
- The mains socket matches the plug. If this is not the case, have the plug replaced.
- The mains socket is adequately grounded. Failure to follow these important safety instructions absolves the manufacturer of all liability.

Warning

1. This appliance is not intended for use by persons (including children) with reduced physical, sensory or mental capabilities, or lack of experience and knowledge, unless they have been given supervision or instruction concerning use of the appliance by a person responsible for their safety.
2. Children should be supervised to ensure that they do not play with the appliance.
3. If the SUPPLY CORD is damaged, it must be replaced by the manufacturer, its service agent or similarly qualified persons in order to avoid a hazard.
4. The appliance shall be installed in accordance with national wiring regulations.
5. Do not use means to accelerate the defrosting process or to clean, other than those recommended by the manufacturer.
6. The appliance shall be stored in a room without continuously operating ignition sources (for example: open flames, an operating gas appliance or an operating electric heater).
7. Do not pierce or burn.
8. Be aware that refrigerants may not contain an odour.
9. The handling, installation, storage, servicing and disposal must comply with the provisions of gas-related national laws and regulations, and also national wiring regulation.
10. It is necessary to clear away the refrigerant in the system when maintaining or scrapping an appliance.



A2L



PARTS NAME

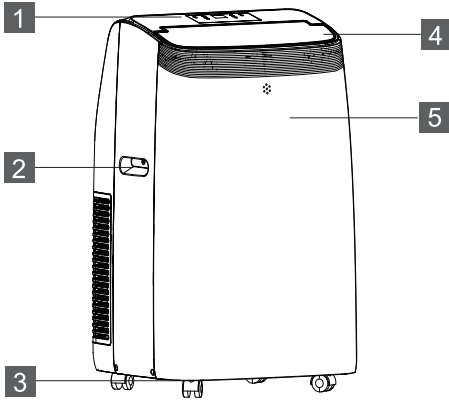



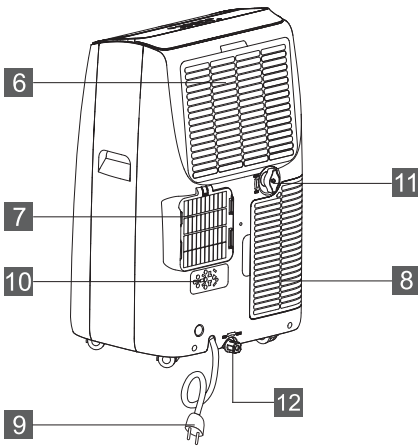

1. Control panel
2. Handle (both sides)
3. Castors
4. Deflector
5. Remote control receiver
6. Intake grille
7. Air outlet grille
8. Intake grille
9. Power cable
10. Universal plug socket
11. Middle drainage
12. Condenser drain

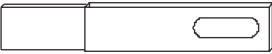

Remote control

Accessories

Parts	Parts name	Quantity
	Exhaust hose Hose outlet Hose inlet	1 set
	Window slider kit	1 set
	Remote Control Batteries (2 * AAA 1.5V)	1 set
	Drain Hose	1 set
	Window Sealing Foam Assembly	1 set

NOTE: All the illustrations in this manual are for explanatory purposes only. Your appliance may be slightly different. Be sure all accessories are removed from the packing before use.

INSTALLATION INSTRUCTIONS

Exhausting hot air

In the Cool Mode the appliance must be placed close to a window or opening so that the warm exhaust air can be ducted outside. First position unit on a flat floor and make sure there's a minimum of 18" (45cm) clearance around the unit, and is within the vicinity of a single circuit outlet power source.

1. Extend either side of the hose (Fig. 1) and screw the hose inlet (Fig. 2).
2. Extend the other side of the hose and screw it to the hose outlet (Fig. 3).
3. Install the hose inlet into the unit (Fig.4).
4. Affix the hose outlet into the window slider kit and seal. (Fig. 5 & 6).

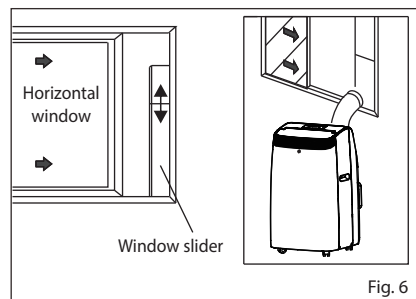
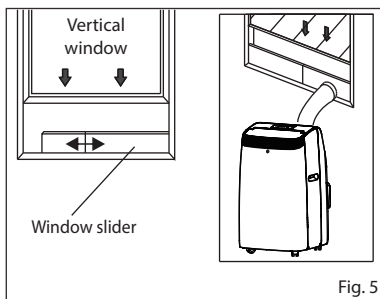
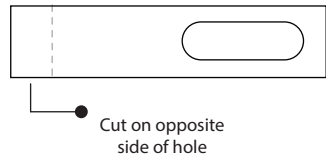
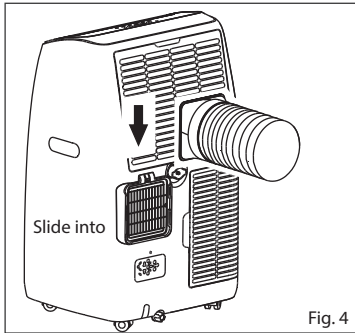
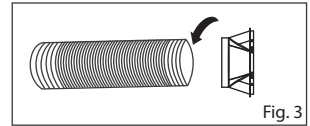
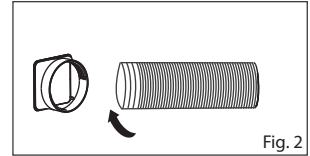
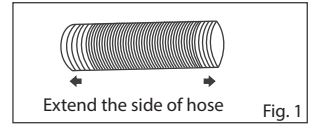

Your window slider kit has been designed to fit most standard vertical and horizontal window applications; however, it may be necessary for you to modify some aspects of the installation procedures for certain types of windows. The window slider kit can be fastened with screws (screws not included).

NOTE: If the window opening is less than the minimum length of the window slider kit, cut the end without the hole in it short enough to fit in the window opening. Never cut out the hole in window slider kit.

Window slider kit installation

1: Parts:

- A) Panel
- B) Panel with hole
- C) Screw to lock window kit in place

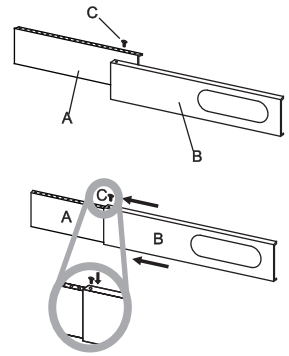

2: Assembly:

Slide Panel A into Panel B and size to window width. Windows sizes vary. When sizing the window width, be sure that the window kit assembly is free from gaps and/or air pockets when taking measurements.

3. Insert the screw into the holes that correspond With the width that your window requires to ensure that there are no gaps or air pockets in the window kit assembly after installation.

1. Cut the foam seal(adhesive type) to the proper length and attach it to the window sash.
2. Attach the window slider kit to the window sash. Adjust the length of the window slider kit according to the width of window. If necessary, mark the kit and cut one end down to properly fit the window.
3. Cut the foam seal(adhesive type) to the proper length and attach it on the top of the window.
4. Close the window securely against the window slider kit.
5. Secure the window slider kit to the window sash.
6. Cut the foam seal to an appropriate length and seal the open gap between the top window frame and outer window frame.

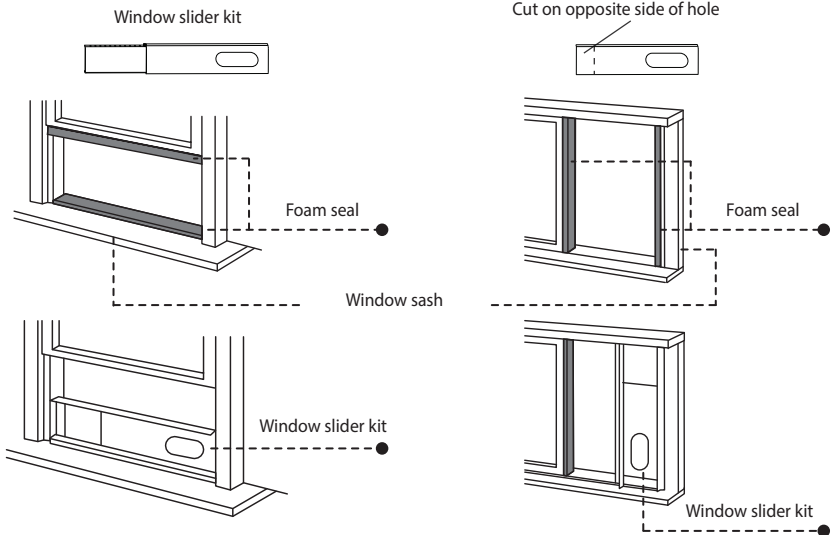

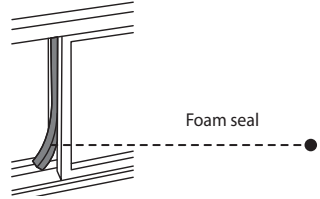
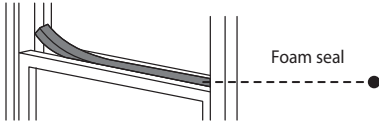
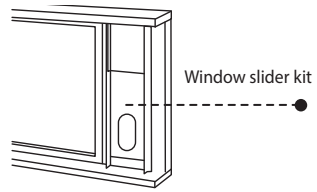
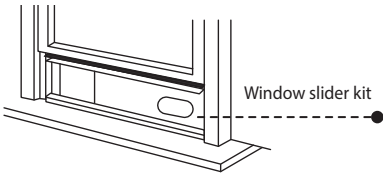

Location

- The unit should be placed on a firm foundation to minimize noise and vibration. For safe and secure positioning, place the unit on a smooth, level floor strong enough to support the unit.
- The unit has casters to aid placement, but it should only be rolled on smooth, flat surfaces. Use caution when rolling on carpeted surfaces. Use caution and Protect floors when rolling over wood floors. Do not attempt to roll the unit over objects.
- The unit must be placed within reach of a properly rated grounded socket.
- Never place any obstacles around the air inlet or outlet of the unit.
- Allow at least 18" (45cm) of around and above space away from the wall for efficient working.
- The hose can be extended, but it is the best to keep the length to minimum required. Also make sure that the hose does not have any sharp bends or dips.

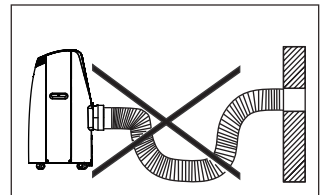
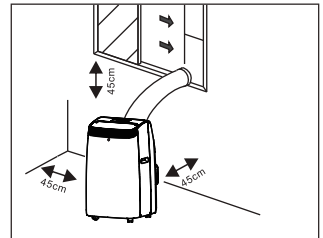

DESCRIPTION OF THE DISPLAY SCREEN

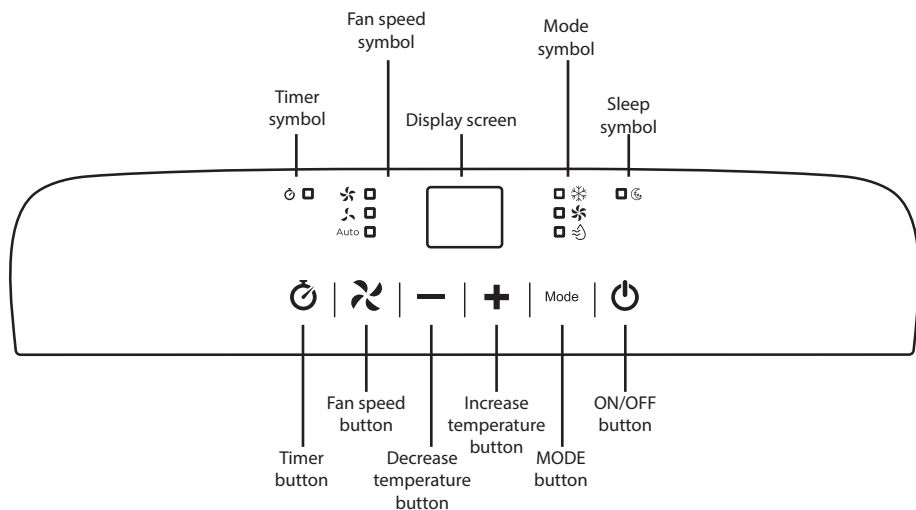

Turning the appliance on

Plug into the main socket, then the appliance in standby mode.

Press the button "⏻" to turn the appliance on. The last function active when it was turned off will appear.



COOL mode

Ideal for hot muggy weather when you need to cool and dehumidify the room.

To set this mode correctly:

- Press the "Mode" button a number of times until the "Cool" symbol appears.
- Select the target temperature 18°C-32°C (64°F-90°F) by pressing the "+" or "-" button until the corresponding value is displayed.
- Select the required fan speed by pressing the "Fan speed" button.



Three speeds are available: High / Low / Auto.

FAN mode

When using the appliance in this mode, the air hose does not need to be attached.

- Press the "Mode" button a number of times until the "Fan" symbol appears.
- Select the required fan speed by pressing the "Fan speed" button.

Two speeds are available: High / Low.

The screen display as high speed as low speed

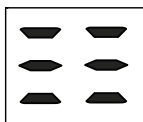

DRY MODE

Ideal to reduce room humidity (spring and autumn, damp rooms rainy periods, etc).

In dry mode, the appliance should be prepared in the same way as for cool mode, with the air exhaust hose attached to enable the moisture to be discharged outside.

To set this mode correctly:

- Press the "Mode" button a number of times until the Dry symbol appears.

The screen display " dh ".

- In this mode, fan speed is selected automatically by the appliance and can not be set manually.



Setting the timer

This timer can be used to delay the appliance start-up or shutdown, this avoids wasting electricity by optimizing operating periods.

Programming start-up

- Turn on the appliance, choose the mode you want, for example Dehumidify mode, high fan speed. Turn off the appliance.
- Press the "⌚" button, the screen starts to flash, press the "+" / "-" to adjust the set time from 0.5-24 hours.
- In 5 seconds without the operation, the timer start function, then the "Timer" symbol lights.
- Press the "⌚" button again to cancel the Timer, and the "Timer" symbol disappear.

* Programming shut down

- When the appliance is running, press the "⌚" button, the screen starts to flash.
- Press the "+" / "-" to adjust the set time from 0.5-24 hours.
- In 5 seconds without operation, the timer starts functioning, then the "Timer" symbol lights.
- Press the "⌚" button again to cancel the Timer, and the "Timer" symbol disappear.

Switch the unit of temperature

When the appliance is running, press "+" and "-" buttons together for 3 seconds, then you can change the unit of temperature.

For example:

Before change, in cool mode, the screen displays like Fig. 1.

After change, in cool mode, the screen displays like Fig. 2.



Fig. 1





Fig. 2

Description of the display screen

Self-diagnosis

The appliance has a self-diagnosis system to identify a number of malfunctions.

Error messages are displayed on the appliance display.

If is displayed	What should i do?
 <p>PROBE FAILURE (sensor damaged)</p>	<p>If this is displayed, contact your local authorized service center.</p>
 <p>FULL TANK (safety tank full)</p>	<p>Empty the internal safety tank, following the instructions in the "End of season operations" paragraph.</p>

REMOTE CONTROL MANUAL

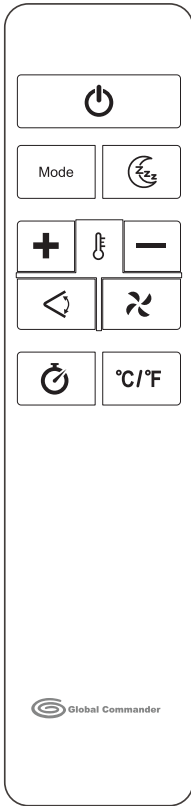

	On/Off button
Mode	Mode button
	Sleep button
	Increase temperature button
	Decrease temperature button
	Swing button
	Fan speed button
	Timer button
°C/°F	Unit Switch button

Point the remote control at the sensor on the appliance.

- ✓ The remote control must be no more than 23ft (7 meters) away from the appliance (without obstacles between the remote control and the receiver).
- ✓ The remote control must be handled with extreme care. Do not drop it or expose it to direct sunlight or sources of heat. If the remote control does not work, check the batteries and replace with new batteries. Do not mix new and old batteries.

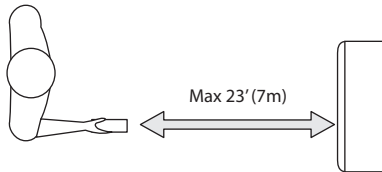

Inserting or replacing the batteries

- Remove the cover on the rear of the remote control.
- Insert two "AAA" 1.5V batteries in the correct position (see instructions inside the battery compartment).

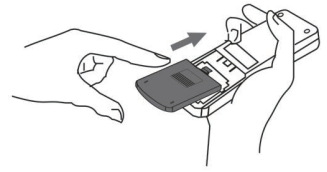

NOTE:

- ✓ If the remote control unit is replaced or disposed of, the batteries must be removed and discarded in accordance with current legislation as they are harmful to the environment.
- ✓ Do not mix old and new batteries. Do not mix alkaline, standard (carbon-zinc) or rechargeable (nickel-cadmium) batteries.
- ✓ Batteries may explode or leak if exposed to open flames. Dispose of batteries accordingly.
- ✓ If the remote control is not being used for extended periods of time (winter storage), remove the batteries and store in a cool, dry location.

COOL mode

Ideal for hot, muggy weather when you need to cooling and dehumidify the room.

To set this mode correctly:

- Press the "Mode" button a number of times until the "Cool" symbol appears.
- Select the target temperature 18°C-32°C(64°F-90°F) by pressing the "+" or "-" button until the corresponding value is displayed.
- Select the required fan speed by pressing the "🌀" button.

Three speeds are available: High / Low / Auto.

The most suitable temperature for the room during the summer varies from 24°C to 27°C(75°F to 81°F). You are recommended, however, not to set a temperature much below the outdoor temperature. The fan speed difference is more noticeable when the appliance is under FAN mode but may not be noticeable under COOL mode.

FAN mode

When using the appliance in this mode, the air hose does not need to be attached.

- Press the "Mode" button a number of times until the "Fan" symbol appears.
- Select the required fan speed by pressing the "🌀" button.

Two speeds are available: High / Low.

The screen display as high speed as low speed

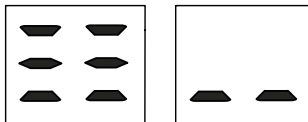

DRY mode

Ideal to reduce room humidity (spring and autumn, damp rooms rainy periods, etc).

In dry mode, the appliance should be prepared in the same way as for cool mode, with the air exhaust hose attached to enable the moisture to be discharged outside.

To set this mode correctly:

- Press the "Mode" button a number of times until the "Dry" symbol appears.

The screen display "dh".

- In this mode, fan speed is selected automatically by the appliance and can not be set manually.



SWING function

This function moves the deflectors to adjust the direction of the air flow.

To set this function correctly:

- Press the "↔" button to select the horizontal deflector to automatically move up and down.
- Press the "↔" button again to switch off this function.

Sleep function

This function is useful for the night as it gradually reduces operation of the appliance.

To set this function correctly:

- Select the cool or heat mode as described above.
- Press the "🌙" button.

The appliance operates in the previously selected mode.

When you choose the sleep function, the screen will reduce the brightness, and the fan speed is low.

The SLEEP function maintains the room at optimum temperature without excessive fluctuations in either temperature or humidity with silent operation.

Fan speed is always at Low, while room temperature and humidity vary gradually to ensure the most comfortable.

When in COOL mode, the selected temperature will increase by 1°C (1°F) per hour in a 2 hour period. This new temperature will be maintained for the next 6 hours.

Then the appliance turn itself off.

When in HEAT mode, the selected temperature will decrease by 1°C (1°F) per hour in a 3 hour period. This new temperature will be maintained for the next 5 hours. Then the appliance turn itself off.

The SLEEP function can be canceled at any time during operation by pressing the "Sleep", "Mode" or "fan speed" button.

In DRY and SMART mode, SLEEP function is still available.

Setting the timer

This timer can be used to delay the appliance startup or shutdown, this avoids wasting electricity by optimising operating periods.

* Programming start-up

- Turn on the appliance, choose the mode you want, for example Dehumidify mode, high fan speed. Turn off the appliance.

- Press the "⌚" button, the screen starts to flash, press the "+" or "-" to adjust the set time from 0.5-24 hours.
- In 5 seconds without the operation, the timer start function, then the "Timer" symbol lights.
- Press the "⌚" button again to cancel the Timer, and the "Timer" symbol disappear.

*** Programming shut down**

- When the appliance is running, press the "⌚" button, the screen starts to flash, press the "+" / "-" to adjust the set time from 0.5-24 hours.
- In 5 seconds without the operation, the timer start function, then the "Timer" symbol lights.
- Press the "⌚" button again to cancel the Timer, and the "Timer" symbol disappear.

Switch from Celsius to Fahrenheit

When the appliance is in running, press the "°C/°F" button and you can change the unit of temperature. For example: Before changing, in Cool mode, the screen will display like the figure on the left. After changing, in Cool mode, the screen will display like the figure on the right.

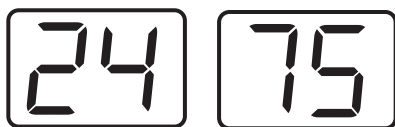

TIPS FOR CORRECT USE

To get the best from your appliance, follow these recommendations:

- Close the windows and doors in the room to be air conditioned (Fig. 11).
When installing the appliance semipermanently, you should leave a door slightly open (as little as 1 cm) to guarantee correct ventilation;
- Protect the room from direct exposure to the sun by partially closing curtains and/or blinds to make the appliance much more economical to run (Fig. 12);
- Never rest objects of any kind on the appliance; (Fig. 13)
- Do not block the air inlet or outlet of the appliance. Reduced air flow will result in poor performance and could damage the unit.
- Make sure there are no heat sources in the room;
- Never use the appliance in very damp rooms (laundries for example).
- Never use the appliance outdoors.
- Make sure the appliance is standing on a level surface. If necessary, place the castor locks under the front wheels.

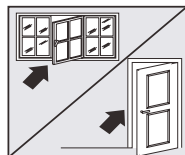

Fig. 11

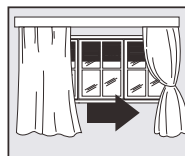

Fig. 12

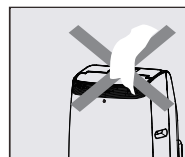

Fig. 13

WATER DRAINAGE METHOD

When there is excess water condensation inside the unit, the appliance stops running and shows "F E" (FULL TANK as mentioned in SELF-DIAGNOSIS). This indicates that the water condensation needs to be drained using the following procedures:

Manual Draining (Fig. 14)

Water may need to be drained in high humidity areas

1. Unplug the unit from power source.
2. Place a drain pan under the lower drain plug. See diagram.
3. Remove the lower drain plug.
4. Water will drain out and collect in the drain pan (maybe not supplied).
5. After the water is drained, replace the lower drain plug firmly.
6. Turn on the unit.

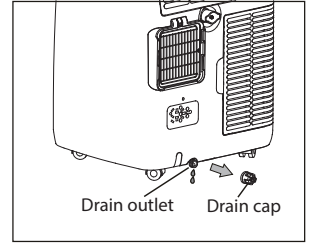

Fig. 14

Middle drainage

When unit running in Dry mode, you can choose the way below to drainage.

1. Unplug the unit from the power source.
2. Remove the drain plug (Fig. A). While doing this operation some residual water may spill so please have a pan to collect the water.
3. Connect the drain hose (1/2" or 12.7mm, maybe not supplied). (Fig. B)
4. The water can be continuously drained through the hose into a floor drain or bucket.
5. Turn on the unit.

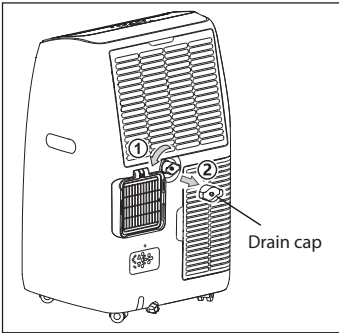

Fig. A

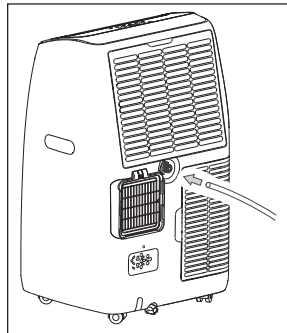
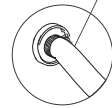

Fig. B

Garden hose or drainage hose



NOTE : Please be sure that the height of and section of the drain hose should not be higher than that of the drain outlet, or the water tank may not be drained. (Fig. C et Fig. D)

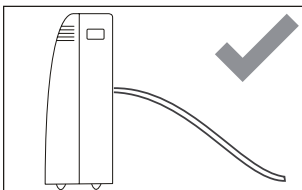

Fig. C

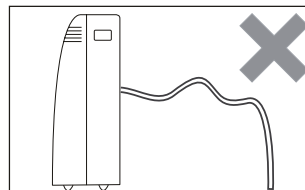

Fig. D

CLEANING

Before cleaning or maintenance, turn the appliance off by pressing the "⏻" button on the control panel or remote control, wait for a few minutes then unplug from the mains socket.

Cleaning the cabinet

You should clean the appliance with a slightly damp cloth then dry with a dry cloth.

- Never wash the appliance with water. It could be dangerous.
- Never use petrol, alcohol or solvents to clean the appliance.
- Never spray insecticide liquids or similar.

Cleaning the air filters

To keep your appliance working efficiently, you should clean the filter every week of operation.

The filter can take out like fig below.

To avoid possible cuts, avoid contacting the metal parts of the appliance when removing or re-installing the filter. It can result in the risk of personal injury.

Use a vacuum cleaner to remove dust accumulations from the filter. If it is very dirty, immerse in warm water and rinse a number of times. The water should never be hotter than 40°C (104°F). After washing, leave the filter to dry then attach the intake grille to the appliance.

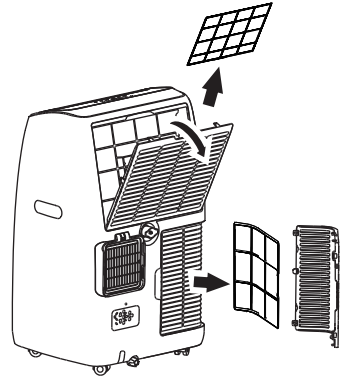

START-END OF SEASON OPERATIONS

Start of season checks

Make sure the power cable and plug are undamaged and the grounding system is efficient. Follow the installation instructions precisely.

End of season operations

To empty the internal circuit completely of water, remove the cap.

Run off all water left into a basin. When all the water has been drained, put the cap back in place.

Clean the filter and dry thoroughly before putting back.

Strictest operation environment:

Cooling mode: 18°C-35°C (64°F-95°F), 30%RH~90%RH

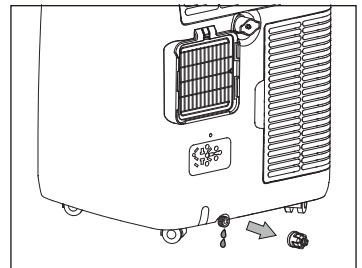

TROUBLESHOOTING

Problem	Cause	Solution
The appliance does not turn on	<ul style="list-style-type: none"> • There is no current • It is not plugged into the mains • The internal safety device has tripped 	<ul style="list-style-type: none"> • Wait • Plug into the mains • Wait 30 minutes, if the problem persists, contact your service center
The appliance works for a short time only	<ul style="list-style-type: none"> • Here are bends in the air exhaust hose • Something is preventing the air from being discharged 	<ul style="list-style-type: none"> • Position the air exhaust hose correctly, keeping it as short and free of curves as possible to avoid bottlenecks • Check and remove any obstacle obstructing air discharge
The appliance works, but does not cool the room	<ul style="list-style-type: none"> • Windows, doors and/or curtains open • There are heat sources in the room (oven, hairdryer, etc.) • The air exhaust hose is detached from the appliance • The technical specification of the appliance is not adequate for the room in which it is located 	<ul style="list-style-type: none"> • Close doors, windows and curtains, bearing in mind the "tips for correct use" given above • Eliminate the heat sources • Fit the air exhaust hose in the housing at the back of the appliance
During operation, there is an unpleasant smell in the room	<ul style="list-style-type: none"> • Air filter clogged 	<ul style="list-style-type: none"> • Clean the filter as described above
The appliance does not operate for about three minutes after restarting it	<ul style="list-style-type: none"> • The internal compressor safety device prevents the appliance from being restarted until three minutes have elapsed since it was last turned off 	<ul style="list-style-type: none"> • Wait. This delay is part of normal operation
The following message appears on the display: PF / FT	<ul style="list-style-type: none"> • The appliance has a self-diagnosis system to identify a number of malfunctions 	<ul style="list-style-type: none"> • See the SELF-DIAGNOSIS Chapter

ASSISTANCE

Distributed by Ouellet Canada Inc.
1 877 247-3461

Before returning the unit to the retailer, for any problem related to the installation, use or proper functioning of the unit; contact our customer support department. One of our agents will guide you through the next steps.

Products have a limited warranty of one year upon presentation of proof of purchase.

Before calling for assistance or service, please check the troubleshooting section. It may save you the cost of a service call.

If you still need help, follow the instructions below. Please know the location and purchase date of your product. Please have in hand the complete model and serial number of your appliance. This information will help us to better respond to your request.

Please record the model and serial number information below. Also, make sure you keep the purchase invoice of your product.

Model Number _____

Serial Number _____

Purchase Date _____

Store Name _____