



WINDOW AIR CONDITIONER

WAT Series

OWNER'S MANUAL
OPERATOR'S MANUAL
TECHNICAL MANUAL

For model:

GJC08BU-A6NRNJ2A

*Please read this owner's manual carefully
before operating the unit and keep it for future reference.*

IMPORTANT : The remote control and hardware necessary to use your new product is included inside the box. You will find them inserted in the Styrofoam included in the box.

TABLE OF CONTENTS

Operation Notices	3
Symbols meanings.....	3
Exception Clauses	4
The Refrigerant.....	5
Refrigerant Safety Precautions	6
General Safety Precautions.....	7
General Instructions for Use.....	10
Installation	12
Parts Name.....	12
Preparation for Installation.....	13
Window Types and Requirements.....	14
Installation Procedure.....	15
Sponge Sticking Method and Procedures.....	18
Function and Control	19
Remote Control.....	21
Air Conditioner Use	23
Instructions for fan direction adjusting.....	23
Normal sounds.....	24
Maintenance	24
Cleaning and Maintenance.....	24
Maintenance Security Precautions	26
Additional Information for Maintenance.....	28
Malfunction Analysis	33
Assistance	37

OPERATION NOTICES

READ THIS MANUAL: Inside you will find many helpful hints on how to use and maintain your air conditioner properly. Just a little preventive care on your part can save you a great deal of time and money over the life of your air conditioner. You'll find many answers to common problems in the chart of troubleshooting tips. If you review our chart of Troubleshooting Tips first, you may not need to call for service at all.

Note: Graphics in this manual are only for reference. Please refer to actual products for specific details.

This appliance is not intended for use by people (including children) with reduced physical, sensory or mental capabilities, or lack of experience and knowledge, unless they have been given supervision or instruction concerning use of the appliance by a person responsible for their safety.

Children should be supervised to ensure that they do not play with the appliance.

CAUTION:

- Contact the authorized service technician for repair or maintenance of this unit.
- Contact the installer for installation of this unit.
- If the SUPPLY CORD is damaged, it must be replaced by the manufacturer, its service agent or similarly qualified people to avoid a hazard.
- Installation work must be performed in accordance with the national wiring standards and by authorized personnel only.

Symbols Meanings



Indicates a risk of fire, caution.



Indicates that before using the appliance, you must read the owner's manual.



Indicates that before installing the appliance, you must read the installation manual.



Indicates that before repairing the appliance, you must read the service manual.

General Warnings:



Indicates NEVER DO THIS.



Indicates ALWAYS DO THIS.

Safety Warnings:



Indicated hazardous situation that, if not avoided, will result in death or serious injury.



Indicated hazardous situation that, if not avoided, could result in death or serious injury.



Indicated hazardous situation that, if not avoided, may result in minor or moderate injury.



Indicates important but not hazard-related information, used to indicate risk of property damage.



Indicates a hazard that would be assigned the mention of WARNING or CAUTION.

Exception Clauses

Manufacturer will bear no responsibilities when personal injury or property loss is caused by the following reasons.

1. Damage to the product due to improper use or misuse of the product;
 2. Alter, change, maintain or use of the product with other equipment without abiding to the instruction manual of manufacturer;
 3. After verification, the defect of product is directly caused by corrosive gas;
 4. After verification, defects are due to improper operation during transportation of product;
 5. Operate, repair, maintain the unit without abiding to instruction manual or related regulations;
 6. After verification, the problem or defect is caused by the quality specification or performance of parts and components that are produced by other manufacturers;
 7. The damage is caused by natural calamities or used in a bad environment.
- If you need to install, move or maintain the air conditioning, please contact the retailer or local service center first. The air conditioning must be installed, moved or maintained by an authorized representative. Otherwise, it could cause serious damage, serious injury or even death.
 - If the refrigerant leaks or requires draining during installation, maintenance or disassembly, a certified professional should be called to take care of the situation.

The Refrigerant

To have a functional air conditioning unit, a special refrigerant circulates in the system. The used refrigerant is the fluoride R32, which is specially cleaned. The refrigerant is flammable and inodorous. Furthermore, it can lead to explosion under certain conditions. But the flammability of the refrigerant is very low. It can be ignited only by fire.

Compared to common refrigerants, R32 is a nonpolluting refrigerant with no harm to the ozone. The greenhouse emissions are also lower. R32 has very good thermodynamic features which leads to a high energy efficiency. The unit therefore needs less filling.

WARNING

- Keep ventilation openings clear of obstruction.
- Do not use means to accelerate the defrosting process or to clean, other than those recommended by the manufacturer.
- Should repair be necessary, contact a qualified technician. Any repairs carried out by unqualified personnel may be dangerous.
- For repairs, strictly follow manufacturer's instructions only.
- Appliance shall be installed, operated and stored in a room with a floor area larger than the recommended area (Please refer to table "1" in section of "Refrigerant Safety Precautions").
- The appliance shall be stored in a room without continuously operating ignition sources (for example: open flames, an operating gas appliance or an operating electric heater).
- Do not pierce or burn the unit.
- Appliance is filled with flammable gas R32.
- Be aware that refrigerants do not contain odor.
- When maintaining or disposing the unit, the refrigerant inside the system must be eliminated. Refrigerant should be recovered. It can't be discharged freely.
- No open fire (fired equipment such as electrical heater and gas stove etc.) or any equipment (e.g. switch) that might generate arc should be around the appliance.

NOTE: Anyone who is involved with working on or breaking into a refrigerant circuit should hold a current valid certificate from an industry-accredited assessment authority, which authorizes their competence to handle refrigerants safely in accordance with an industry recognized assessment specification. Servicing shall only be performed as recommended by the equipment manufacturer. Maintenance and repair requiring the assistance of skilled personnel shall be carried out under the supervision of the person competent to use flammable refrigerants.



Refrigerant Safety Precaution

Qualification requirement for installation and maintenance

Everyone who is working with a refrigeration system should bear the valid certification awarded by the authorized organization and the qualification for dealing with the refrigeration system recognized by this industry.

Installation reminders

- The air conditioner cannot be installed in a room that has running fire or such fire source.
- The air conditioner must be installed in a room that is larger than the minimum room area. (See Table 1 below).
- Leak test is a must after installation.

Table 1: Minimum room area (m²)

Charge amount (kg)	≤1.2	1.3	1.4	1.5	1.6	1.7	1.8	1.9	2.0	2.1	2.2	2.3	2.4	2.5
Floor location	/	14.5	16.8	19.3	22.0	24.8	27.8	31.0	34.3	37.8	41.5	45.4	49.4	53.6
Window mounted	/	5.2	6.1	7.0	7.9	8.9	10.0	11.2	12.4	13.6	15.0	16.3	17.8	19.3
Wall mounted	/	1.6	1.9	2.1	2.4	2.8	3.1	3.4	3.8	4.2	4.6	5.0	5.5	6.0
Ceiling mounted	/	1.1	1.3	1.4	1.6	1.8	2.1	2.3	2.6	2.8	3.1	3.4	3.7	4.0

Welding Instructions - Must be done by a qualified technician

If you should cut or weld the refrigerant system pipes during maintenance, please follow the steps below:

1. Shut down the unit and cut power supply.
2. Eliminate the refrigerant.
3. Vacuum.
4. Clean it with N2 gas.
5. Cut or weld.
6. Carry back to the service spot for welding.

NOTE: The refrigerant should be recycled into a specialized storage tank.



WARNING: Make sure there isn't any naked flame near the outlet of the vacuum pump and that is well-ventilated.

Instructions to fill the Refrigerant- Must be done by a qualified technician

1. Use the refrigerant filling appliances specialized for R32. Make sure that different kinds of refrigerant won't contaminate with each other.
2. The refrigerant tank should be kept upright at the time of filling refrigerant.
3. Stick the label on the system after filling is finished.
4. Don't overfill.
5. After filling is finished, please do the leakage detection test before using the unit.

General Safety Precautions

To prevent injury to the user or other people and property damage, the following instructions must be followed. Incorrect operation may cause harm or damage.

- ❗ Plug in power plug properly. Otherwise, it may cause electric shock or fire due to excess heat generation.
- ❗ Always ensure effective grounding. Incorrect grounding may cause electric shock.
- ❗ Unplug the unit if strange sounds, smell or smoke comes from it.
- ❗ Keep firearms away. It may cause fire.
- ❗ Ventilate room before operating air conditioner if there is a gas leakage from another appliance. It may cause explosion, fire and burns.
- ❗ Always install circuit breaker and a dedicated power circuit. Incorrect installation may cause fire and electric shock.
- ❗ Ensure that the installation bracket of the outdoor appliance is not damaged due to prolonged exposure.
- ❗ Ventilate the room well when used together with a stove, as an oxygen shortage may occur.
- ❗ When the unit is to be cleaned, switch off and turn off the circuit breaker.
- ❗ Stop operation and close the window in a storm or hurricane.
- ❗ Turn off the main power switch when not using the unit for a long time. It may cause failure of product or fire.
- ❗ Always insert the filters securely. Clean the filter once every two weeks. Operation without filters may cause failure.
- ❗ Use a soft cloth to clean the unit.
- ❗ If water enters the unit, turn the unit off at the power outlet and switch off the circuit breaker. Isolate supply by taking the power plug out and contact a QUALIFIED SERVICE TECHNICIAN.
- ❗ Use caution when unpacking and installing. Sharp edges could cause injury.
- ❗ Maintenance must be performed by qualified professionals. Otherwise, it may cause personal injury or damage.



WARNING

- ⊗ Do not place obstacles around air-inlets or inside of air-outlets. It may cause failure of appliance or an accident.
- ⊗ Do not operate or stop the unit by inserting or pulling out the power plug. It may cause electric shock or fire due to heat generation.
- ⊗ Do not damage or use an unspecified power cord.
- ⊗ If the power supply wire is damaged, it must be replaced by a qualified person in order to avoid a hazard.
- ⊗ Do not modify power cord length or share the outlet with other appliances. It may cause electric shock or fire due to heat generation.
- ⊗ Do not hold the plug by the head when taking it out. It may cause electric shock and damage.
- ⊗ Do not use strong detergent such as wax or thinner to clean the unit. The appearance may be deteriorated due to change of product color or scratching of the surface.
- ⊗ Do not operate with wet hands or in damp environment. It may cause electric shock.
- ⊗ Do not direct airflow at room occupants directly. It could damage your health.
- ⊗ Do not allow water to run into electric parts. It may cause failure of machine or electric shock.
- ⊗ Do not use the socket if it is loose or damaged. It may cause fire or electric shock.
- ⊗ Do not use the power cord close to heating appliances. It may cause fire or electric shock.
- ⊗ Do not use the power cord near flammable gas or combustibles, such as gasoline, benzene, thinner, etc. it may cause an explosion or fire.
- ⊗ Do not disassemble or modify unit. It may cause failure or electric shock.
- ⊗ Do not open the unit during operation. It may cause electric shock.
- ⊗ When the air filter is to be removed, do not touch the metal parts of the unit. It may cause injury.
- ⊗ Do not clean the air conditioner with water. Water may enter the unit and degrade the insulation. It may cause electric shock.
- ⊗ Do not place heavy objects on the power cord and ensure that the power cord is not compressed. There is danger of fire or electric shock.
- ⊗ Do not drink water drained from air conditioner. It contains contaminants and could make you sick.
- ⊗ Do not put a pet or house plant where it will be exposed to direct air flow. This could cause injury.
- ⊗ Do not use for special purposes (i.e. preserve precision devices, food, pets, plants and art objects). It may cause deterioration of quality, etc.
- ⊗ Do not clean unit when power is on as it may cause fire and electric shock. It may cause an injury.
- ⊗ Do not connect air conditioner to multipurpose socket. Otherwise, it may cause fire hazard.
- ⊗ Do install the air switch ((thermal-magnetic breaker). If not, it may cause malfunction.
- ⊗ Do not spill water on the remote controller, otherwise the remote controller may be broken.
- ⊗ Do not spray water on air conditioner. It may cause electric shock or malfunction.
- ⊗ Do not extend fingers or objects into air inlet or air outlet. It may cause personal injury or damage.
- ⊗ Do not step on or put heavy objects on air conditioner. It may cause damage or personal injury.



WARNING

The power supply cord with this air conditioner contains a current detection device designed to reduce the risk of fire. Please refer to the section "Instructions for use" for details.

If the power supply cord is damaged, it cannot be repaired. It must be replaced with a cord from the product manufacturer.



WARNING

For your safety

- Do not store or use gasoline or other flammable vapors and liquids near this or any other appliance.
- Avoid fire hazard or electric shock. Do not use an extension cord or an adaptor plug. Do not remove any prong from the power cord.

Electrical Information

- Be sure the electrical service is adequate for the model you have chosen. This information can be found on the serial plate, which is located on the side of the cabinet and behind the grill.
- Be sure the air conditioner is properly grounded. To minimize shock and hazards, proper grounding is important. The power cord is equipped with a three-prong grounding plug for protection against shock hazards.
- Your air conditioner must be used in a properly grounded wall receptible. If the wall receptible you intend to use is not adequately grounded or protected by a time delay fuse or circuit breaker, have a qualified electrician install the proper receptible.
- Ensure the receptible is accessible after the unit installation.
- Do not run air conditioner without side protective cover in place. This could result in mechanical damage within the air conditioner.
- Do not, under any circumstances, cut, remove or bypass the grounding prong.
- Do not use an extension cord or an adapter plug.

General Instructions for Use

Power supply

The power supply cord contains a current device that senses damage to the power cord. To test your power supply cord, do the following:

1. Plug in the Air Conditioner.
2. The power supply cord will have TWO buttons on the plug head. Press the TEST button, you will notice a click as the RESET button pops up.
3. Press the RESET button, again you will notice a click as the button engages.
4. The power supply cord is now supplying electricity to the unit. (On some products this is also indicated by a light on the plug head.)

NOTICE:

- Do not use this device to turn the unit on or off.
- Always make sure the RESET button is pushed in for correct operation.
- The power supply must be replaced if it fails reset when either the TEST button is pushed, or it cannot be reset. Please contact customer service.
- If power supply cord is damaged, it cannot be repaired. It **MUST** be replaced with a new cord. Please contact customer service.

NOTE: The power cord of window type unit has creepage protection device.

There is a test button and a reset button on the plug. You are suggested to check the power cord periodically.

Check method: After putting through the power, the indicator is ON. After pressing the TEST button, the indicator is OFF and you can hear a sound. Then press the RESET button, the indicator will be ON, which indicates the protection device is normal.

NOTE: Plug may be different with the actual product. Please refer to actual product.

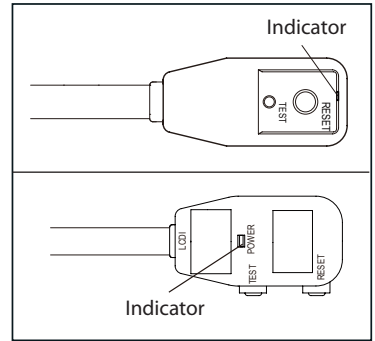

Operating temperature range

	Indoor side DB/WB (°C/°F)	Outdoor side DB/WB (°C/°F)
Maximum Cooling	40°C (104°F) / 26.7°C (80°F)	40°C (104°F) / 26.7°C (80°F)

The operating temperature range (outdoor temperature) for cooling unit only is 18°C to 40°C (64.4°F to 104°F).



WARNING

Security precautions

1. You must follow the electric safety regulations when installing the unit.
2. According to the local safety regulations, use a qualified power supply circuit and air switch (thermal-magnetic breaker).
3. Make sure the power supply matches with the requirement of air conditioner. Unstable power supply or incorrect wiring may result in electric shock, fire hazard or malfunction.
4. Properly connect the live wire, neutral wire and grounding wire of power socket.
5. Be sure to cut off the power supply before proceeding any work related to electricity and safety.
6. Do not put the power on before finishing installation.
7. The air conditioner is a first-class electric appliance. It must be properly grounded. Please make sure it is always grounded effectively, otherwise it may cause electric shock.
8. Do not use for other purposes the yellow-green wire or green wire in air conditioner other than for grounding.
9. The grounding resistance should comply with national electric safety regulations.
10. Make sure the power supply complies with the requirement of air conditioner. Unstable power supply or wrong wiring may lead to electric shock.

Electric wiring

- Must connect with ground reliably.
- The exclusive circuit must be used. But removable socket can't be used because poor contact of it can cause overheat or cause fire.
- Don't pull the power cord strongly.
- Connecting method between air conditioners and power cord and interconnecting method of each individual element with one another should be done according to the wiring diagram on the unit.
- The air conditioner should be installed in accordance with national wiring regulation.
- An all-pole disconnection switch having a contact separation of at least 3 mm (1/8") in all poles should relate to fixed wiring.
- Air switch (thermal-magnetic breaker) should be installed in the circuit.

INSTALLATION



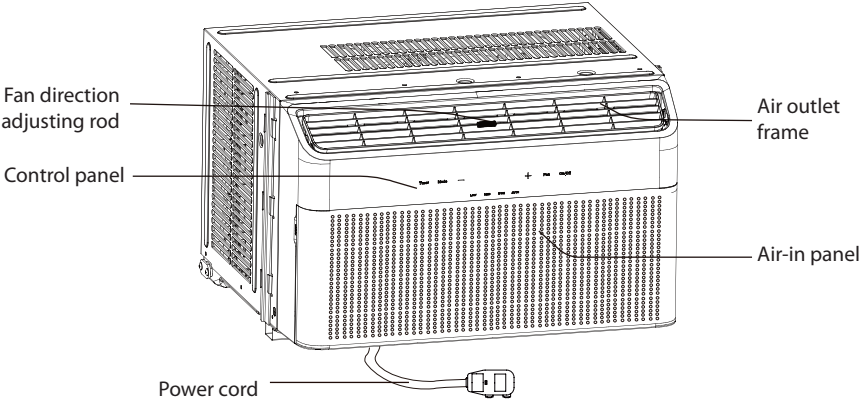

Parts Name

NOTE: Panel outlook picture, just for reference, please take the real unit as standard.



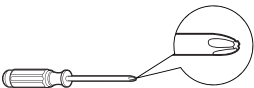



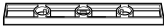
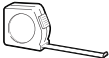



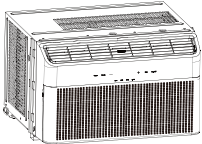

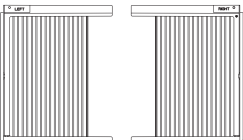
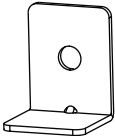

Preparation for Installation

Tools for installation

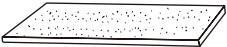
Phillips screwdriver		Scissors	
Screwdriver		Pencil	
Level bar		Measuring tape	

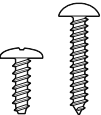
Components included in the box - may vary from model to model

Air conditioner		Lock frame (2) (For wooden windows)	
Left and right accordion panel		Window locking bracket	
Window sill and sash seal (2)		Foam top window gasket	
Top mounting rail seal strip		Top mounting rail	
Accordion panel seal (2)		Foam Insulation (2)	
Remote controller		Type A screws(4) And Type B screws(6)	
Batteries		User Manual	

Window Types and Requirements

NOTE:

- The description for below installation is for the standard window. If it's other types of window, you may need to adjust the window.
- If you need to install the air conditioner at the small window, you may not need to use the flexible screen sub-assy. Please refer to requirement of window size for details.
- All parts used for supporting air conditioner should be fixed at solid wooden strap, brick or metal.
- Socket must be installed at the position where the power cord is available.

Standard window

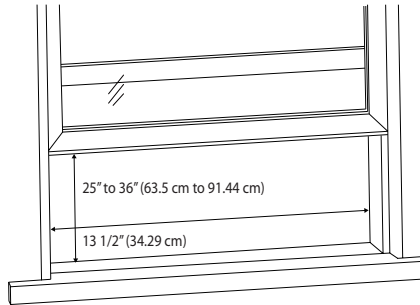

Weather-proof type window

- The height of window frame is higher than windowsill for some weather-proof type window, which will affect the installation of air conditioner. In this case, before installing the air conditioner, add wooden strap on the windowsill, and fix the wooden strap at the windowsill.

- Specification of wooden strap

Width: about 2"

Length: same to the inner frame size of window

Height: Put the wooden strap on the windowsill, top part of wooden strap and window frame should be at the same horizontal level, or higher than the top part of window frame about 1/4"-1/2".

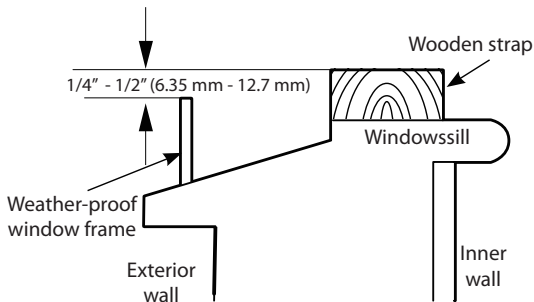

Installation Procedure

Location

How to install:

- Choose a location where there are no any obstacle surrounding the unit, and the plug is accessible.
- Choose the installation space according to the following diagram.
The distance between the air conditioner and the around obstacles should meet the requirement as below: over 300 mm (upper side), over 500 mm (left side), over 500 mm (right side), over 1500 mm (front side) and over 500mm (rear side).

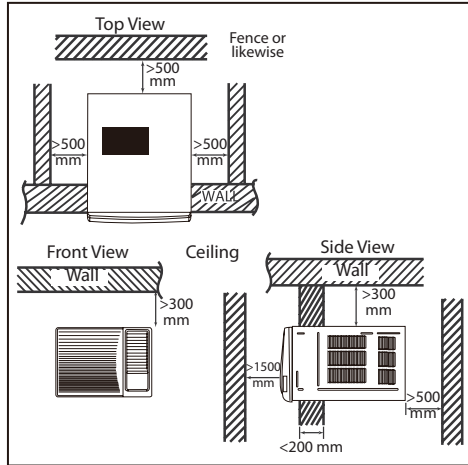
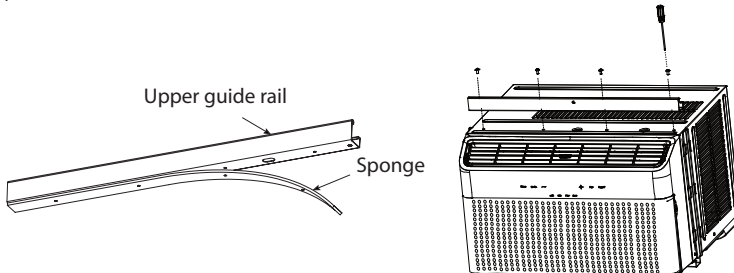

Figure A

Step 1: Install top mounting rail

1. Tear off the paster at back side of top mounting rail seal strip, and then align it at the bottom edge of top mounting rail to stick the top mounting rail seal strip at the bottom of top mounting rail. (The top mounting rail seal strip has been stick on the top mounting rail for some models. Therefore, this step can be omitted.)
2. Use 4 type A screws to fix the top mounting rail at the outer case of air conditioner. (The top mounting rail has been fixed on the conditioner for some models. Therefore, this step can be omitted.)



Step 2: Install accordion panel

1. Stick one accordion panel seal respectively on the left side and right side of accordion panel installation frame, as shown in the figure.

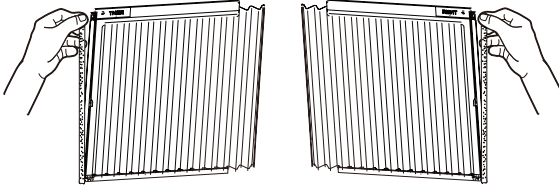

2. Undraw the accordion panel, install the accordion panel marked with "LEFT" "RIGHT" at both sides of air conditioner in turn. Slide the upper and lower ends of accordion panel into upper and lower guide rails.

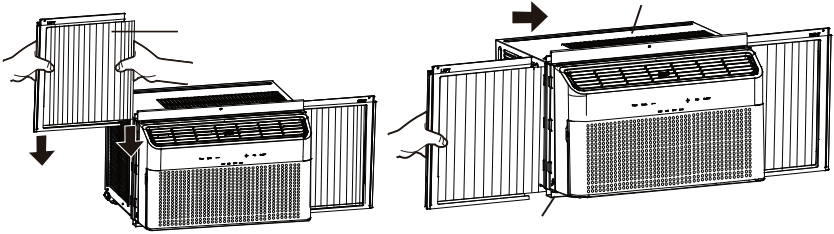

Step 3: Stick window sill and sash seal

- Cut the Window sill and sash seal into proper length. Tear off the paster and then stick the seal at the lower part of the window frame.

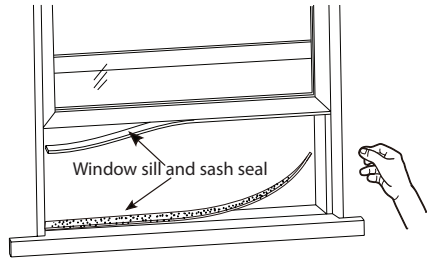

Step 4: Put the air conditioner

1. Ask 2 persons to put the air conditioner at the windowsill, and the lower guide rail should be stick at the windowsill. Top mounting rail stays at the middle lower side of window and then window can stick to the top mounting rail when closing it. Please note that the air conditioner should be placed at horizontal place or inclined outwards slightly.

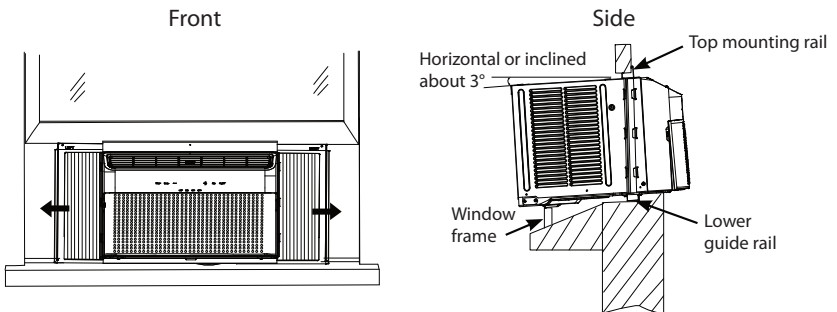

2. Pull the window, undraw accordion panels at both sides to keep it vertical to the window frame and then use 5 type B screws to fix the frame of accordion panel at window frame and window-sill.

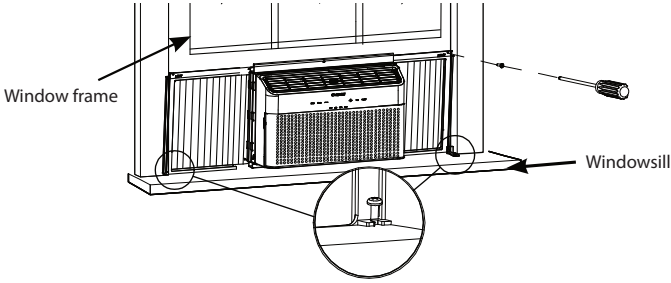

Step 5: Install window locking bracket

Install the window locking bracket at the window frame to fix the window.

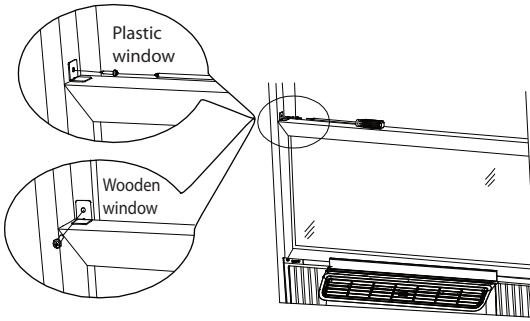

Step 6: Plug foam top window gasket

Cut the foam top window gasket into the length same to the width of window. Plug the foam between glasses and window to prevent rain and insects getting into the room.

Note: If Foam top window gasket is not proper to your window, you can select other proper materials.

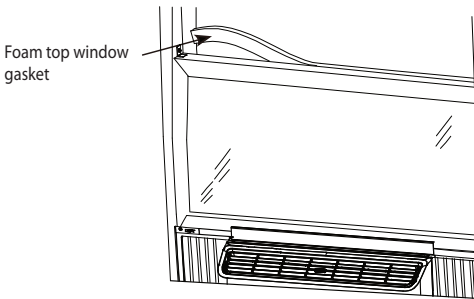

Step 7: Drain water

To get the maximum cooling efficiency, the air conditioner is designed to splash the condensate on the condenser coil. If the splashing sound annoys you, you can provide an outside drain by using the following procedure, which may however cause a small loss of performance.

1. The air conditioner have the drainage gasket-Figure 1.
2. Remove the drainage gasket from the body base plate-Figure 2.

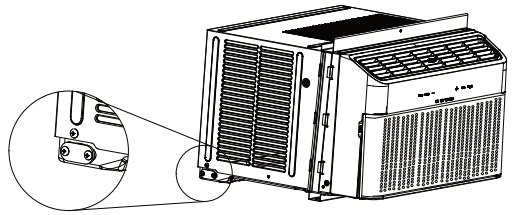

Figure 1

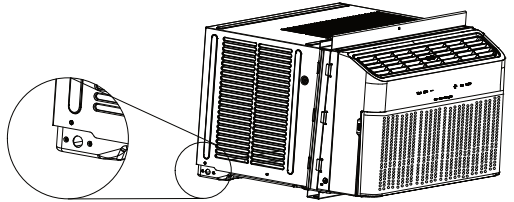
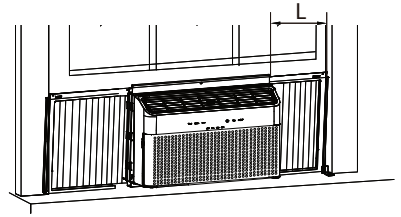

Figure 2

Sponge Sticking Method and Procedures

1. Install accordion panel sub-assy. After finishing installation, measure the width L between outer case of air conditioner and window frame.



2. Take out foam insulation from the package. Cut off the foam insulation in rectangular shape with scissors.

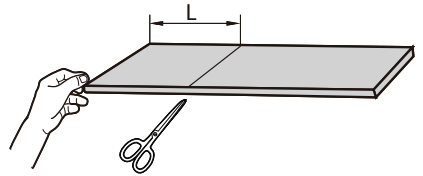

3. Stick foam insulation evenly on the accordion panel and the screen of window frame. The redundant 2~3 mm of foam insulation in height can be stuffed into the frame for fixing.

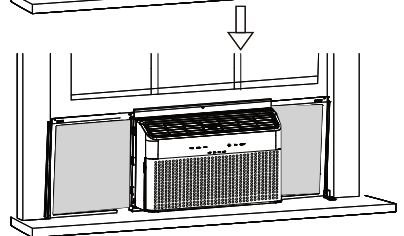
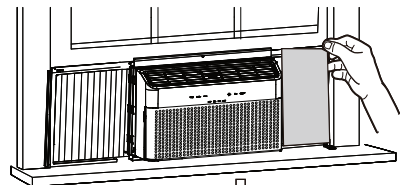

FUNCTION AND CONTROL

After putting through the power, air conditioner will give out a sound and indicators on control panel will be on. After that, you operate the air conditioner through remote controller or control panel.

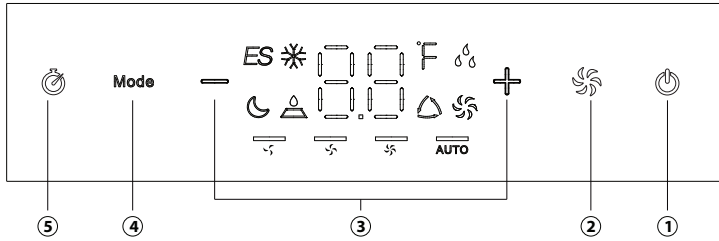

1 On/Off button
2 Fan button

3 + / - button
4 Mode button

5 Timer button

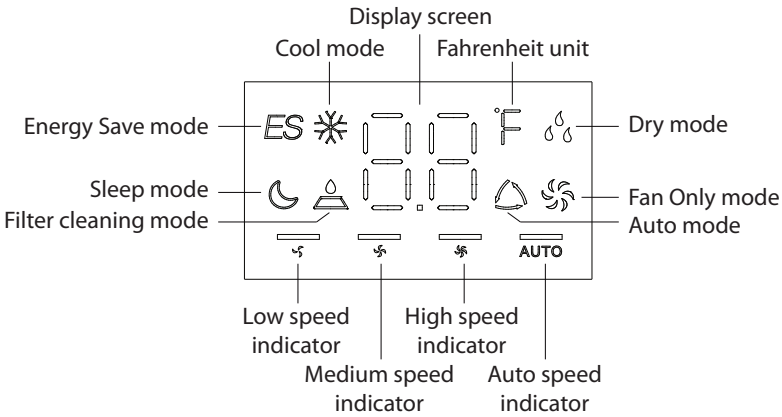

NOTICE: “” when fan has operated for 250h accumulatively, filter cleaning icon is on to remind user for cleaning filter; when filter cleaning icon is on (fan has operated for 250h accumulatively), Press and hold “Time” button and “-” button simultaneously for 3s to clear accumulative operation time of filter and then filter cleaning icon is off.

1. On/Off button

Control unit on and off. Under unit off status, press this button to enter energy save mode; under unit on status, press this button to enter unit off status.

2. FAN button

Pressing this button can set fan speed circularly as below:

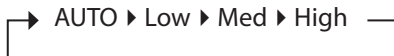

3. +/- button

- Under timer setting status, press this button to set time from 0.5 to 24. When setting time is within 10h, time will increase or decrease 0.5h after each pressing of "+" or "-" button; when setting time is among 10~24h, time will increase or decrease 1h after each pressing of "+" or "-" button.
- Under non-timer setting status, set temperature will increase or decrease 1°F (1°C) after each pressing of "+" or "-" button.
- Under temperature setting or timer setting status mentioned above, holding on pressing "+" or "-" button, temperature or timer will increase or decrease automatically.
- Under temperature setting or timer setting, temperature setting will be confirmed after finishing setting for 3 seconds and timer setting will be confirmed after finishing setting for 5 seconds.
- Press Timer button and "-" button simultaneously for 3s to clear the accumulative operation time of filter.
- Under unit on status, press "+" button and "-" button simultaneously for 3s to switch between Fahrenheit and Centigrade.

4. Mode button

Pressing this button can set mode circularly as below:

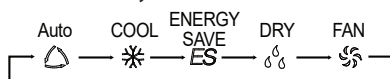

5. TIMER BUTTON

- **Timer setting:**
Pressing Timer button can set timer and dual-8 nixie tube displays time value. In this case, press "+" or "-" button to adjust time from "--" to 24h. After finishing setting for 5s, the system will automatically confirm and enter timer status. If dual-8 nixie tube displays "--", the system will exit timer setting status after 5s.
- **Timer preview:**
Under timer status, press Timer button to enter timer preview. In this case, dual-8 nixie tube displays residual time. In timer preview, if timer time is adjusted and confirmed, timer time will be recalculated.
Notice: precision of timer preview: when it is less than 10h, the displayed precision is 0.5; when it is more than 10h, the displayed precision is 1. For example, when the remaining time is 4 hours and 15 minutes, the dual-8 display will be 4.5.
- **Cancel timer:**
If timer off has been set, press Timer button twice in 5s to cancel timer off. If timer on has been set, press Timer button twice in 5s to cancel timer on.

Remote Control

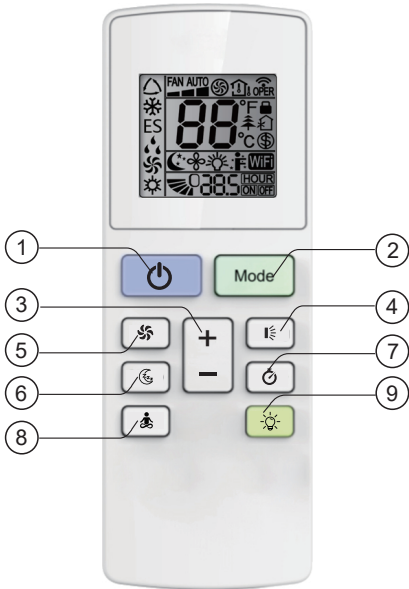

NOTE: This is a general use remote controller, it could be used for the air conditioners with multifunction; For some function, which the model doesn't have, if press the corresponding button on the remote controller that the unit will keep the original running status.

- 1 ON/OFF button
- 2 MODE button
- 3 + / - button
- 4 SWING button (function not available for this model)
- 5 FAN button
- 6 SLEEP button
- 7 TIMER button
- 8 I FEEL button
- 9 LIGHT button

1.ON/OFF button

Press this button to turn on the unit, turning on the unit with remote controller, the unit will operate in energy-saving mode. Press this button again to turn off the unit. NOTE: If energize the unit and turn it on, or turn it off and then turn it on, the unit will operate in energy-saving mode; if the unit is energized after power failure, the unit will still operate according to the status before power failure.

2. MODE button

Press this button, your required modes will be operated in turn. Corresponding indicator will be on.

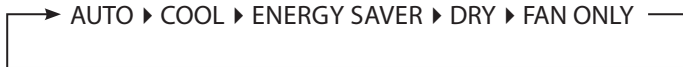

- **Auto:** Under this mode, the unit will operate automatically according to ex-factory setting. In this case, set temperature cannot be adjusted.
- **Cool:** Under this mode, air conditioner operates under cooling mode. Cooling indicator will be on. Press "Fan Speed" button can adjust the fan speed.
- **Energy Saver:** under this mode, air conditioner operates SE mode. SE indicator will be on. Press "Fan Speed" button can adjust the speed.
- **Dry:** Under this mode, the unit runs in low fan speed for dehumidification and the corresponding indicator is on; under dry mode, the fan speed cannot be adjusted.
- **Fan Only:** Under this mode, air conditioner will not cool or heat, only blow wind. Fan indicator will be on. Press "Fan Speed" button can adjust the fan speed. (No auto fan speed under fan mode)

3. + / - button

- Pressing "+" or "-" button once will increase or decrease set temperature by 1°F (°C). Hold "+" or "-" button for 2 seconds, set temperature on remote controller will change quickly. Release the button after your required set temperature is reached.
- Under timer setting status, after each pressing of "+" or "-" button, time will increase or decrease 0.5h . Hold "+" or "-" button, 2 seconds later, time displayed on dual-8 nixie tube will change quickly. Loosen the button until the time is reached to your set time.

4. SWING button

Note: Swing function is not available for this model.

5. FAN button

This button is used to adjust the fan speed in a sequence from AUTO, speed 1, speed 2, speed 3 then back to AUTO.

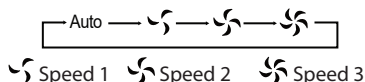

NOTE: There are 3 speeds for the Fan Speed of this model.

6. SLEEP button

Press this button to go into the SLEEP operation mode. Press it again to cancel this function. This function is available in COOL, SAVE or DRY mode to maintain the most comfortable temperature for you.

7. TIMER button

Under ON status, press this button to set timer OFF; Under OFF status, press this button to set timer ON.

Press this button once and the characters of HOUR ON (OFF) will flash to be displayed. Meanwhile, press "+" button or "-" button to adjust timer setting (time will change quickly if holding "+" or "-" button). Time setting range is 0.5~24 hours. Press this button again to confirm timer setting and the characters of HOUR ON (OFF) will stop flashing.

If the characters are flashing but you haven't press timer button, timer setting status will be quit after 5 seconds. If timer is turned on, press this button again to cancel timer.

8. I FEEL button

I feel function will be action if pressing this button. If controller receives I FEEL order, it will work under ambient temperature value which sending by remote controller, and remote controller will send ambient temperature value to controller every 10min. After 11min, if controller does not receive ambient temperature value which sending by remote controller, it will run with AC ambient temperature; if I FEEL is not set, ambient temperature will adopt sampling value of AC temperature sensor. If power off happens, this function will not be memorized.

9. LIGHT button

Turn on the display's light and press this button again to turn off the display's light. If the light is turned on,  is displayed. If the light is turned off, disappears.

Function introduction for combination buttons

Temperature display switchover function

Under OFF status, press "-" and "Mode" buttons simultaneously to switch temperature display between °C and °F.

Replacement of Batteries in Remote Controller

1. Press the back side of remote controller marked with "OPEN", as shown in the figure, and then push out the cover of battery box along the arrow direction.
2. Replace two 7# (AAA 1.5V) dry batteries, and make sure the position of "+" polar and "-" polar are correct.
3. Reinstall the cover of battery box.

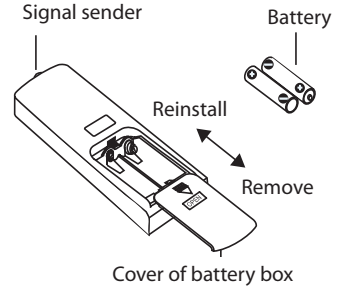

NOTICE:

- The distance between signal sender and receiving window should be no more than 8 m, and there should be no obstacles between them.
- As the signal will be interfered in the room with electronic fluorescent lamp, conversion fluorescent lamp or wireless phone, please get closer to the air conditioner when using the remote controller.
- Replace new batteries of the same model when replacement is required.
- When you don't use remote controller for a long time, please take out the batteries.

AIR CONDITIONER USE

Instruction for fan direction adjusting

You can adjust the fan direction adjusting rod to select left&right air outlet direction according to your requirement.

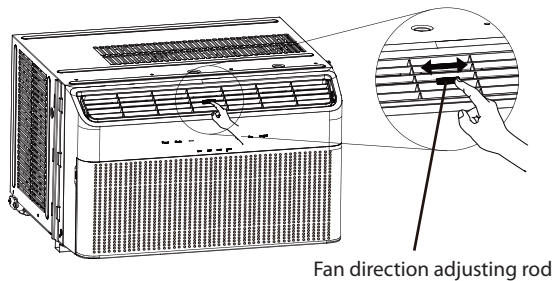

You can adjust the air outlet frame to select up&down air outlet direction according to your requirement.

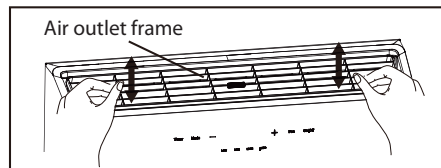

Normal Sounds

When your air conditioner is operating normally, you may hear sounds such as:

- Droplets of water hitting the condenser, causing a pinging or clicking sound. The water droplets help cool the condenser.
- Air movement from the fan.
- Clicks from the thermostat cycle.
- Vibrations or noise due to poor wall or window construction.
- A high-pitched hum or pulsating noise caused by the modern high-efficiency compressor cycling on and off.

MAINTENANCE

Cleaning and Maintenance

WARNING

- Turn off the air conditioner and disconnect the power before cleaning the air conditioner to avoid electric shock.
- Do not wash the air conditioner with water to avoid electric shock.
- Do not use volatile liquid to clean the air conditioner.

Clean filter

1. Open the panel
Pull the groove at both sides of panel forcibly to open the panel to a certain angle as shown in the figure.
2. Remove the filter.
Remove the filter as shown in the figure.
3. Clean the filter
Use dust catcher or water to clean the filter.
If the filter is very dirty, you can use the warm water (below 45 degree) dissolved with neutral abluent, and then put it under the shady place.
When cleaning the filter, you are suggested to clean the cellular round hole on the air-in pnael at the same time.
4. Install the filter
Install the filter and then buckle the panel cover tightly.

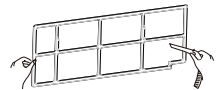
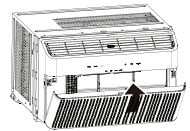
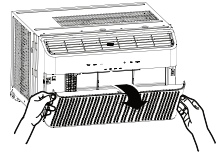

WARNING

- Clean the filter about once every three month. Of there are lots of dust in operation environment, you can increase the clean times.
- Due to there's shaft metal fins in the air conditioner, do no touch the fins after removing filter to avoid scratching.
- Do not dry the filter on fire or use hair drier to dry the filter. Otherwise, the filter may be deformed or catch fire.
- Do not operate the air conditioner when the filter hasn't been installed.

Cabinet Cleaning

NOTE: Be sure to unplug the air conditioner to prevent shock or fire hazard.

WARNING: Never use harsh cleaners, wax or polish on the cabinet front.

1. The cabinet and front may be dusted with an oil-free cloth or wash with a cloth dampened in dishwashing liquid detergent and warm water.
2. Rinse thoroughly and wipe dry.
3. Be sure to wring excess water from the cloth before wiping around the controls. Excess water in or around the controls may cause damage to the air conditioner.
4. Once cleaning is done, plug back the air conditioner.

Cleaning the Front Panel

NOTE: Do not remove the panel when cleaning it.

1. Unplug air conditioner or disconnect power.
2. Clean front panel with a soft dry or wet cloth.
3. Air dry front panel completely.
4. Plug in air conditioner or reconnect power.

Repairing Paint Damage

Check once or twice a year for paint damage. This is very important, especially in areas near oceans or where rust is problem. If needed, touch up with a good grade enamel paint.

NOTE: To reduce paint damage during the winter, install a heavy-duty cover over air conditioner cabinet.

Annual Maintenance

Your air conditioner needs annual maintenance to help ensure steady, top performance throughout the year. Call your local authorized dealer to schedule an annual checkup. The expense of an annual inspection is your responsibility.

Winter Storage

If you plan to store the air conditioner during the winter, remove it carefully from the window according to the installation instructions. Cover it with plastic or return it to the original carton.

Qualifications of Workers

Qualification of the working personnel for maintenance, service and repair operations should according to CAS/UL 60335-2-40:17 Annex HH. Every working procedure that affects safety means shall only be carried out by competent persons according to Annex HH. Special training additional to usual refrigerating equipment repair procedures is required when equipment with FLAMMABLE REFRIGERANTS is affected.

Maintenance Security Precautions

- ❶ Check whether the maintenance area or the room area meets the requirement on the name plate. It's only allowed to be operated in the rooms that meet the requirements on the name plate.
- ❷ Check whether the maintenance area is well-ventilated. The continuous ventilation status should be kept during the operation process.
- ❸ Check whether there is a fire source or potential fire source in the maintenance area. The naked flame is prohibited in the maintenance area. The no-smoking sign should be hanged.
- ❹ Check whether the appliance mark is in good condition. Replace the vague or damaged warning mark.

Storing the unit

1. Do not puncture or light the unit.
2. The unit shall be stored in a room without continuous fire source (e.g. naked fire, litten gas appliance, operating electric heater).
3. The unit shall be stored in a ventilated place; the ventilation device shall operate normally, and ventilation port shall be without obstacle.
4. Check the unit periodically to see if there is collision mark and if the appearance is good.
5. Check the electronic components (e.g. cable) periodically to see if there is breakage.
6. Do not collapse the unit to avoid leakage of refrigerant; if leakage is found, please arrange ventilation immediately and ask professionals for maintenance, to avoid a fire hazard.

Disposing and recycling of the unit - Must be done by a qualified technician

Disposal:

The technician shall be familiar with the device and all its characteristics before disposal. Proceeding to safe recycling of refrigerant is recommended. If the recycled refrigerant shall be utilized, please analyze the sample of refrigerant and oil before proceeding. Please ensure the required power supply before testing. Please take the following operation:

1. Be familiar with the device and its operation.
2. Cut off power supply.
3. Make sure the following items are respected before proceeding:
 - Mechanical operation device shall be convenient for the operation of refrigerant tank;
 - All personal protection apparatuses shall be workable, and they are used correctly;
 - The whole recycle procedure shall be done under the instruction of qualified person;
 - The recycled device and refrigerant tank shall comply with relevant standards.
4. Please arrange vacuum pumping to the refrigeration system. If vacuum status cannot be reached, please arrange vacuum pumping from several positions to recycle the refrigerant in different parts of the system.
5. Make sure the capacity of refrigerant tank is sufficient before recycling.
6. Start and operate the recycled device according to the operation instruction of manufacturer.
7. Make sure the refrigerant tank is not too full (the filled liquid shall not exceed 80% of the capacity of refrigerant tank).
8. Do not exceed the maximum operation pressure.
9. Remove the refrigerant tank and device quickly after finishing operation and make sure all cut-off valves in the device are closed.
10. The recycled refrigerant cannot be filled into another refrigeration system before purification and inspection.

Label:

The unit shall be labeled with data and note after scrapping and discharging refrigerant. Make sure the label on the unit can reflect the R32 refrigerant which it has been filled.

Recycle:

It's recommended to remove the refrigerant from the system before maintenance and disposal.

To recycle, put the refrigerant into the specialized refrigerant tank with refrigerant label. The refrigerant tank shall be equipped with pressure-relief valve and cut-off valve, if they are in good condition. If possible, the empty tank should be dealt with vacuum pumping before using and keep it at normal temperature.

Recycling device shall be kept in good working status and equipped with operation instructions for reference. The device shall be applicable for the recycle of R32 refrigerant. In addition, qualified weighing apparatus which can be used normally shall be prepared. The hose shall adopt removable connector without leakage for connection and keep it in good status. Check if the recycling device is in normal status before using it and if it is properly stored with all electrical components sealed to prevent fire hazard caused by refrigerant leakage. If you have any question, please consult a qualified technician.

The recycled refrigerant shall be put in proper containers attached with transportation instruction and send it back to the refrigerant manufacturer. Do not mix different refrigerants in the refrigerant recycle device, especially the refrigerant tank.

When disassembling the compressor or clearing the compressor oil, make sure the compressor has been dealt with vacuum pumping to suitable level, so that no R32 refrigerant remains in the lubricant. Vacuum pumping shall be done before the compressor is sent back to the supplier. Only electric heating can be adopted for heating the shell of compressor to speed up the course. When oil is drained from the system, please ensure safety.

Additional Information for Maintenance Must be done by a qualified technician

Area Check

Prior to beginning work on systems containing FLAMMABLE REFRIGERANTS, safety checks are necessary to ensure that the risk of ignition is minimised.

General Work Area

- All maintenance staff and others working in the local area shall be instructed on the nature of the work being carried out.
- Work in confined spaces shall be avoided.
- The area around the workspace shall be sectioned off.
- Ensure that the conditions within the area have been made safe by control of flammable material.

Checking for presence of refrigerant

The area shall be checked with an appropriate refrigerant detector prior to and during work, to ensure the technician is aware of potentially toxic or flammable atmospheres. Ensure that the leak detection equipment being used is suitable for use with all applicable refrigerants (i.e. non-sparking, adequately sealed or intrinsically safe).

Presence of fire extinguisher

If any hot work is to be conducted on the refrigeration equipment or any associated parts, appropriate fire extinguishing equipment shall be available to hand. Have a dry powder or CO₂ fire extinguisher adjacent to the charging area.

No ignition sources

All possible ignition sources, including cigarette smoking, should be kept sufficiently far away from the site of installation, repairing, removing and disposal, during which refrigerant can possibly be released to the surrounding space. Prior to work taking place, the area around the equipment is to be surveyed to make sure that there are no flammable hazards or ignition risks. "No Smoking" signs shall be displayed.

Ventilated area

Ensure that the area is in the open or that it is adequately ventilated before breaking into the system or conducting any hot work. A degree of ventilation shall continue during the period that the work is carried out. The ventilation should safely disperse any released refrigerant and preferably expel it externally into the atmosphere.

Checks to the refrigeration equipment

Where electrical components are being changed, they shall be fit for the purpose and to the correct specification. At all times the manufacturer's maintenance and service guidelines shall be followed. If in doubt, consult a qualified technician.

The following checks shall be applied to installations using FLAMMABLE REFRIGERANTS:

- The charge size is in accordance with the room size within which the refrigerant containing parts are installed.
- The ventilation machinery and outlets are operating adequately and are not obstructed.
- If an indirect refrigerating circuit is being used, the secondary circuit shall be checked for the presence of refrigerant.

- Marking to the equipment continues to be visible and legible. Markings and signs that are illegible shall be corrected.
- Refrigeration pipe or components are installed in a position where they are unlikely to be exposed to any substance which may corrode refrigerant containing components, unless the components are constructed of materials which are inherently resistant to being corroded or are suitably protected against being so corroded.

Checks to electrical devices

Repair and maintenance to electrical components shall include initial safety checks and component inspection procedures. If a fault exists that could compromise safety, then no electrical supply shall be connected to the circuit until it is satisfactorily dealt with. If the fault cannot be corrected immediately but it is necessary to continue operation, an adequate temporary solution shall be used. This shall be reported to the owner of the equipment, so all parties are advised.

Initial safety checks shall include:

- Capacitors are discharged: this shall be done in a safe manner to avoid possibility of sparking.
- No live electrical components and wiring are exposed while charging, recovering or purging the system.
- There is continuity of earth bonding.

Repairs to sealed components

During repairs to sealed components, all electrical supplies shall be disconnected from the equipment being worked upon prior to any removal of sealed covers, etc. If it is absolutely necessary to have an electrical supply to equipment during servicing, then a permanently operating form of leak detection shall be located at the most critical point to warn of a potentially hazardous situation. Particular attention shall be paid to the following to ensure that by working on electrical components, the casing is not altered in such a way that the level of protection is affected. This shall include damage to cables, excessive number of connections, terminals not made to original specification, damage to seals, incorrect fitting of glands, etc.

- Ensure that the apparatus is mounted securely.
- Ensure that seals or sealing materials have not degraded to the point that they no longer serve the purpose of preventing the ingress of flammable atmospheres.
- Replacement parts shall be in accordance with the manufacturer's specifications.

Repair to intrinsically safe components

Do not apply any permanent inductive or capacitance loads to the circuit without ensuring that this will not exceed the permissible voltage and current permitted for the equipment in use. Intrinsically safe components are the only types that can be worked on while live in the presence of a flammable atmosphere. The test apparatus shall be at the correct rating. Replace components only with parts specified by the manufacturer. Other parts may result in the ignition of refrigerant in the atmosphere from a leak.

Cabling

Check that cabling will not be subject to wear, corrosion, excessive pressure, vibration, sharp edges or any other adverse environmental effects. The check shall also consider the effects of aging or continual vibration from sources such as compressors or fans.

Detection of flammable refrigerants

Under no circumstances shall potential sources of ignition be used in the searching for or detection of refrigerant leaks. A halide torch (or any other detector using a naked flame) shall not be used.

Leak detection methods

The following leak detection methods are deemed acceptable for all refrigerant systems:

- Electronic leak detectors may be used to detect refrigerant leaks but, in the case of FLAMMABLE REFRIGERANTS, the sensitivity may not be adequate, or may need re-calibration. Detection equipment shall be calibrated in a refrigerant-free area.
- Ensure that the detector is not a potential source of ignition and is suitable for the refrigerant used. Leak detection equipment shall be set at a percentage of the LFL of the refrigerant and shall be calibrated to the refrigerant employed, and the appropriate percentage of gas (25 % maximum) is confirmed.
- Leak detection fluids are suitable for use with most refrigerants but the use of detergents containing chlorine shall be avoided as the chlorine may react with the refrigerant and corrode the copper pipe-work.

If a leak is suspected, all naked flames shall be removed/extinguished.

If a leakage of refrigerant is found which requires brazing, all the refrigerant shall be recovered from the system, or isolated (by means of shut off valves) in a part of the system remote from the leak.

For appliances containing FLAMMABLE REFRIGERANTS, oxygen free nitrogen (OFN) shall then be purged through the system both before and during the brazing process.

Removal and evacuation

When breaking into the refrigerant circuit to make repairs or for any other purpose, conventional procedures shall be used. However, for flammable refrigerants it is important that the best practice is. Opening of the refrigeration systems shall not be done by brazing. The following procedure shall be adhered to:

1. Remove refrigerant.
2. Purge the circuit with inert gas.
3. Evacuate.
4. Purge again with inert gas.
5. Open the circuit by cutting or brazing.

The refrigerant charge shall be recovered into the correct recovery cylinders. For appliances containing FLAMMABLE REFRIGERANTS, the system shall be "flushed" with OFN to render the unit safe. This process may need to be repeated several times. Compressed air or oxygen shall not be used for purging refrigerant systems.

For appliances containing FLAMMABLE REFRIGERANTS, flushing shall be achieved by breaking the vacuum in the system with OFN and continuing to fill until the working pressure is achieved, then venting to atmosphere, and finally pulling down to a vacuum. This process shall be repeated until no refrigerant is found within the system. When the final OFN charge is used, the system shall be vented down to atmospheric pressure to enable work to take place. This operation is vital if brazing operations on the pipework are to take place.

Ensure that the outlet for the vacuum pump is not close to any ignition sources and that ventilation is available.

Charging procedures

In addition to conventional charging procedures, the following requirements shall be followed:

- Ensure that contamination of different refrigerants does not occur when using charging equipment. Hoses or lines shall be as short as possible to minimise the amount of refrigerant contained in them.
- Cylinders shall be kept upright.
- Ensure that the refrigeration system is earthed prior to charging the system with refrigerant.
- Label the system when charging is complete (if not already).
- Extreme care shall be taken not to overfill the refrigeration system.
- Prior to recharging the system, it shall be pressure-tested with the appropriate purging gas. The system shall be leak-tested on completion of charging but prior to commissioning.
- A follow up leak test shall be carried out prior to leaving the site.

Decommissioning

Before carrying out this procedure, it is essential that the technician is completely familiar with the equipment and all its detail. It is recommended good practice that all refrigerants are recovered safely.

Prior to the task being carried out, an oil and refrigerant sample shall be taken in case analysis is required prior to re-use of reclaimed refrigerant. It is essential that electrical power is available before the task is commenced.

1. Become familiar with the equipment and its operation.
2. Isolate system electrically.
3. Before attempting the procedure, ensure that:
 - Mechanical handling equipment is available.
 - All personal protective equipment is available and being used correctly.
 - The recovery process is always supervised by a competent person.
 - The recovery equipment and cylinders conform to the appropriate standards.
4. Pump down refrigerant system, if possible.
5. If a vacuum is not possible, make a manifold so that refrigerant can be removed from various parts of the system.
6. Make sure that cylinder is situated on the scales before recovery takes place.
7. Start the recovery machine and operate in accordance with manufacturer's instructions.
8. Do not overfill cylinders. (No more than 80 % volume liquid charge).
9. Do not exceed the maximum working pressure of the cylinder, even temporarily.
10. When the cylinders have been filled correctly and the process completed, make sure that the cylinders and the equipment are removed from site promptly and all isolation valves on the equipment are closed off.
11. Recovered refrigerant shall not be charged into another refrigeration system unless it has been cleaned and checked.

Labelling

Equipment shall be labelled stating that it has been decommissioned and emptied of refrigerant. The label shall be dated and signed. For appliances containing FLAMMABLE REFRIGERANTS, ensure that there are labels on the equipment stating the equipment contains flammable refrigerant.

Recovery

- When removing refrigerant from a system, either for servicing or decommissioning, it is recommended good practice that all refrigerants are removed safely.
- When transferring refrigerant into cylinders, ensure that only appropriate refrigerant recovery cylinders are employed. Ensure that the correct number of cylinders for holding the total system charge are available.
- All cylinders to be used are designated for the recovered refrigerant and labelled for that refrigerant.
- Cylinders shall be complete with pressure-relief valve and associated shut-off valves in good working order.
- Empty recovery cylinders are evacuated and, if possible, cooled before recovery occurs.
- The recovery equipment shall be in good working order with a set of instructions concerning the equipment that is at hand and shall be suitable for the recovery of all appropriate refrigerants including, when applicable, FLAMMABLE REFRIGERANTS.
- A set of calibrated weighing scales shall be available and in good working order.
- Hoses shall be complete with leak-free disconnect couplings and in good condition.
- Before using the recovery machine, check that it is in satisfactory working order, has been properly maintained and that any associated electrical components are sealed to prevent ignition in the event of a refrigerant release. Consult manufacturer if in doubt.
- The recovered refrigerant shall be returned to the refrigerant supplier in the correct recovery cylinder, and the relevant waste transfer note arranged. Do not mix refrigerants in recovery units and especially not in cylinders.
- If compressors or compressor oils are to be removed, ensure that they have been evacuated to an acceptable level to make certain that flammable refrigerant does not remain within the lubricant. The evacuation process shall be carried out prior to returning the compressor to the suppliers. Only electric heating to the compressor body shall be employed to accelerate this process. When oil is drained from a system, it shall be carried out safely.

MALFUNCTION ANALYSIS

Malfunction code:

When there's abnormal phenomenon for the air conditioner, dual-8 nixie tube displays corresponding malfunction code:

Code	Solution
E2	An-freezing protection
F0	System insufficient refrigerant and blockage protection
H3	Compressor overload protection
U8	Zero-crossing inspection circuit fault of PG motor
H6	PG motor blockage protection
E8	High temperature prevention protection
F1	Indoor ambient temperature sensor is open/short-circuited
F2	Indoor evaporator temperature sensor is open/short-circuited
F4	Outdoor condenser temperature sensor is open/short-circuited
C5	Jumper cap fault protection





WARNING

- If there's below phenomenon, please turn off the air conditioner and disconnect the power immediately. After that, please contact dealer at once.
 - Power cord is overheating or damaged.
 - There's abnormal sound during operation.
 - There's burning smell.
 - Power cord test or reset button often bounces automatically.
 - Water leakage at indoor side.
- Do not repair or readjust the air conditioner by yourself.
- Operating the air conditioner under abnormal circumstances will cause malfunction, electric shock or fire hazard.

You can solve many common air conditioner problems easily, saving you the cost of a service call. Try the suggestions below to see whether you can solve your problem without needing to use outside help.

Issue	Possible Causes	Solution
Air conditioner will not operate.	The power supply cord is unplugged.	Plug into grounded 3 prong outlet.
	There is a power failure.	Wait after power recovery.
	The power supply cord trips (Reset button will pop out).	Press and release RESET (listen for click; Reset button will latch and on some devices, a green light will turn on) to resume operation. See below for more details.
	A household fuse has blown, or circuit breaker has tripped.	Replace the fuse or reset the circuit breaker. See below for more details.
	Depending on model, the Power button has not been pressed or the Fan Speed control is turned to Off.	Press POWER button or turn the FAN SPEED control to an active setting.
	The local power has failed.	Wait for power to be restored.
Air conditioner blows fuses or trips circuit breakers.	Too many appliances are being used on the same circuit.	Unplug or relocate appliances that share the same circuit.
	Time-delay fuse or circuit breaker of the wrong capacity is being used.	Replace with a time-delay fuse or circuit breaker of the correct capacity.
	An extension cord is being used.	Do not use an extension cord with this or any other appliance.
	You are trying to restart the air conditioner too soon after turning the unit off.	Wait at least 3 minutes after turning the unit off before trying to restart the air conditioner.
Air conditioner power supply cord trips (Reset button pops out).	Disturbances in your electrical current can trip (Reset button will pop out) the power supply cord.	Press and release RESET (listen for click; Reset button will latch and on some devices, a green light will turn on) to resume operation.
	An electrical overloading, overheating, pinching or aging can trip (Reset button will pop out) the power supply cord .	After correcting the problem, press and release RESET (listen for click; Reset button will latch and on some devices, a green light will turn on) to resume operation.
	NOTE: A damaged power supply cord must be replaced with a new power supply cord obtained from the product manufacturer. A damaged power supply cord must not be repaired.	
Temperature can't be adjusted	Is the temperature operating under auto or fan mode?	The temperature cannot be adjusted under auto or fan mode
	Does the required temperature exceeds the allowed temperature interval?	The temperature can only be adjusted between 61°F (16°C) and 86°F (30°C)
There is an odour	There's a source of odour in the room such as furniture, cigarettes, etc.	Eliminate odour source.
		Clean filter

Issue	Possible Causes	Solution
Air conditioner seems to run too much.	The current air conditioner replaced an older model.	The use of more efficient components may cause the air conditioner to run longer than an older model, but the total energy consumption will be less. Newer air conditioners do not emit the “blast” of cold air you may be accustomed to from older units, but this is not an indication of lesser cooling capacity or efficiency. Refer to the efficiency rating (EER) and capacity rating (in BTU/hr.) marked on the air conditioner.
	The air conditioner is in a heavily occupied room, or heat producing appliances are in use in the room.	Use exhaust vent fans while cooking or bathing and try not to use heat producing appliances during the hottest part of the day. A higher capacity air conditioner may be required, depending on the size of the room being cooled.
Water drips from cabinet into your house.	The air conditioner is not properly leveled.	The air conditioner should slope slightly downward toward the outside. Level the air conditioner to provide a downward slope toward the outside to ensure proper drainage. See the Installation Instructions.
	NOTE: Do not drill a hole in the bottom of the metal base and condensate pan.	
Air conditioner can't receive signal from remote controller or remote controller is not sensible.	The unit is interfered seriously (such as static pressure, unstable voltage).	Please pull out the plug. Insert the plug after about 3 minutes, and then turn on the unit.
	Remote controller is not within the receiving range.	The receiving range of remote controller is 8 m (26.25'). Do not exceed this range.
	It's blocked by obstacles.	Remove the obstacles
	Sensitivity of remote controller low.	Check the batteries of remote controller. If the power is low, please replace the batteries.
	There's a fluorescence lamp in the room.	Move the remote controller close to the air conditioner. Turn off lamp and try it again.
There is an abnormal sound when operation is working	Could there be an interference such as radio, thunder, etc.?	Turn the appliance off, disconnect it, re-connect it and turn it on.

Issue	Possible Causes	Solution
Air conditioner cycles on and off too much or does not cool.	The Mode is set to Power Saver (on some models).	Use Power Saver only when you are away from home or asleep, since the fan does not circulate the room air continuously. Use Low, High or Turbo for your best comfort.
	The air conditioner is not properly sized for your room.	Check the cooling capabilities of your room air conditioner. Room air conditioners are not designed to cool multiple rooms.
	The filter is dirty or obstructed by debris.	Clean the filter.
	The inside evaporator and outside condenser coils are dirty or obstructed by debris.	See "Annual Maintenance" in the cleaning and maintenance section.
	There is excessive heat or moisture (open container cooking, showers, etc.) in the room.	Use a fan to exhaust heat or moisture from the room. Try not to use heat producing appliances during the hottest part of the day.
	The louvers are blocked.	Install the air conditioner in a location where the louvers are free from curtains, blinds, furniture, etc.
	The outside temperature is below 65 °F (18°C).	Do not try to operate your air conditioner in the cooling mode when the outside temperature is below 65°F (18°C).
	The temperature of the room you are trying to cool is extremely hot.	Allow extra time for the air conditioner to cool off a very hot room.
	Windows or doors to the outside are open.	Close all windows and doors.
	The Exhaust control is set to OPEN (on some models).	Push the Exhaust control CLOSED for maximum cooling.
	Depending on model, the  /  or  control is not at a cool enough setting.	Adjust the  /  control to a cooler setting by pressing the minus button to reduce the temperature or adjust the TEMPERATURE control to a cooler setting by turning the knob clockwise. Set the FAN SPEED control to highest setting (Turbo or High, depending on model).
You can hear the sound of water circling	Is the appliance on or did you just turn it off?	This is a normal sound. It is simply the sound of the refrigerant circling through the machine.
You can hear a friction or a knocking sound	Is the appliance on or did you just turn it off?	The appliance internal panel is expanding or shrinking according to the temperatures changes, which causes a sound of friction.

ASSISTANCE

Distributed by Ouellet Canada Inc.
1 877 247-3461

Before returning the unit to the retailer, for any problem related to the installation, use or proper functioning of the unit; contact our customer support department. One of our agents will guide you through the next steps.

Products have a limited warranty of one year upon presentation of proof of purchase.

Before calling for assistance or service, please check the troubleshooting section. It may save you the cost of a service call.

If you still need help, follow the instructions below. Please know the location and purchase date of your product. Please have in hand the complete model and serial number of your appliance. This information will help us to better respond to your request.

Please record the model and serial number information below. Also, make sure you keep the purchase invoice of your product.

Model Number _____

Serial Number _____

Purchase Date _____

Store Name _____

